



K73 - ADJOIN Workstation Panel Measurement Kit

**K73 Hardware Kit Includes:**  
 Caliper (1) 900-01120

**Materials/Tools Required:**  
 Tape Measure

**Application 1a: Panel Stacker Measurements**

Provide measurements of desking system partitions as shown. Complete field measurements (Application 1c) and return to Takeform.

All measurements other than F to be to the nearest 1/16".

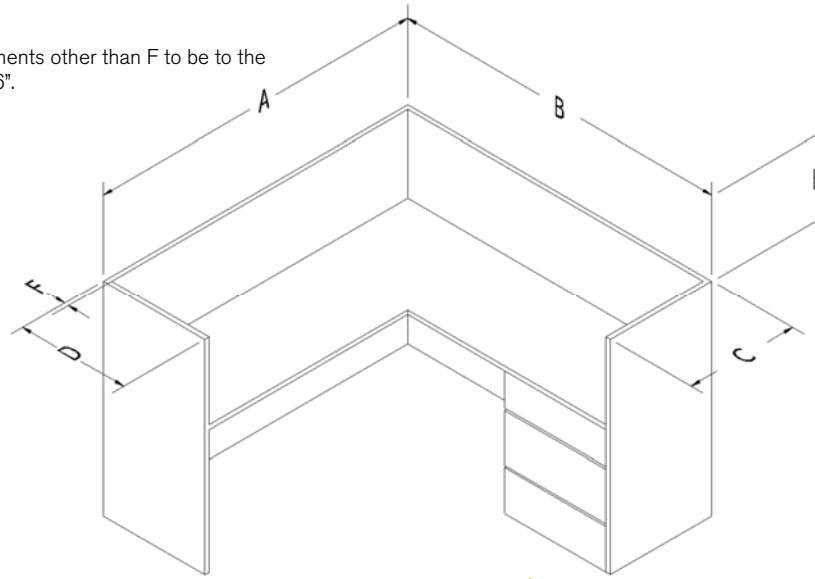

Panel Adapter

**Declaration:**

1. For an optimal fit, client provides Takeform with a completed field measurement guide + visuals of workstation (ideally photos and/or CAD or other technical drawing specifying dimensions). Our team will adjust sizes where necessary to account for slight gap between panels and at corners.

2. Alternatively, if you don't provide visuals, we'll fabricate panels to client specifications. For best fit, leave 1/4" gap between panels and at corners.

**Application 1b: Partition Measurements and Photo**

Use caliper for measurement F (partition thickness) as shown. **Take picture as illustrated** so we can accurately size panel stacker adapters. Make sure numbers on caliper are legible.



**Application 1c: Field Measurements**

Please complete to ensure accurate sizing of panels and adapters.

- A : Desk Length \_\_\_\_\_
- B : Desk Width \_\_\_\_\_
- C : Desk Return Wall Length (if applicable) \_\_\_\_\_
- D : Desk Return Wall 2 Length (if applicable) \_\_\_\_\_
- E : Desired Panel Height (up to 23.5" max) \_\_\_\_\_
- F : Partition Thickness (include photo w/caliper) \_\_\_\_\_
- G : Adapter Color (black, white or gray) \_\_\_\_\_
- H : Desk System Mfg. / Model # / Wall Material \_\_\_\_\_
- J : Take photos that provide an overall view of workstation system. See page 4 for photo examples. Please note any obstructions.



**K73 Hardware Kit Includes:**

Caliper (1) 900-01120

**Materials/Tools Required:**

Tape Measure

**Declaration:**

1. For an optimal fit, client provides Takeform with a completed field measurement guide + visuals of workstation (ideally photos and/or CAD or other technical drawing specifying dimensions). Our team will adjust sizes where necessary to account for slight gap between panels and at corners.

2. Alternatively, if you don't provide visuals, we'll fabricate panels to client specifications. For best fit, leave 1/4" gap between panels and at corners.

**Application 2a: Adapter-mounted Desktop Partition Measurements**

Provide measurements of desk as shown. Complete field measurements (Application 2c) and return to Takeform.

All measurements other than D to be to the nearest 1/16".

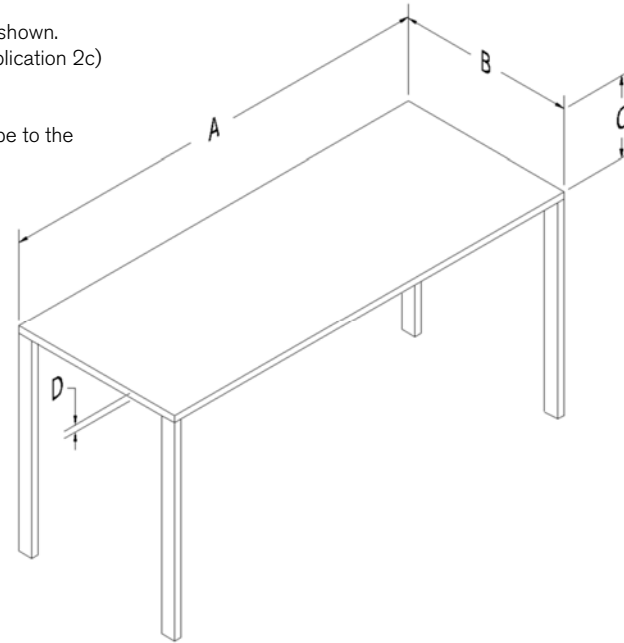

"C" Adapter to Desktop

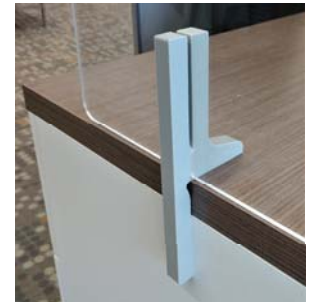

"L" Adapter to Desktop

**Application 2b: Desktop Measurements and Photo**

Use caliper for measurement D (desktop thickness) as shown. **Take picture as illustrated** so we can accurately size panel adapters. Make sure numbers on caliper are legible.



**Application 2c: Field Measurements**

Please complete to ensure accurate sizing of panels and adapters.

- A : Desk Length \_\_\_\_\_
- B : Desk Width \_\_\_\_\_
- C : Desired Panel Height (up to 23.5" max) \_\_\_\_\_
- D : Desktop Thickness (include photo w/caliper) \_\_\_\_\_
- E : Adapter Color (black, white or gray) \_\_\_\_\_
- F : Desk System Mfg. / Model # / Wall Material \_\_\_\_\_
- G : Take photos that provide an overall view of workstation system. See page 4 for photo examples. Please note any obstructions.

K73 Hardware Kit Includes:  
 Caliper (1) 900-01120

Materials/Tools Required:  
 Tape Measure

**Declaration:**

1. For an optimal fit, client provides Takeform with a completed field measurement guide + visuals of workstation (ideally photos and/or CAD or other technical drawing specifying dimensions). Our team will adjust sizes where necessary to account for slight gap between panels and at corners.

2. Alternatively, if you don't provide visuals, we'll fabricate panels to client specifications. For best fit, leave 1/4" gap between panels and at corners.

**Application 3a: Freestanding Desktop Partition Measurements**  
 Provide measurement of desired freestanding panel height to a maximum of 36" and desktop width as shown. Complete field measurements (Application 3b) and return to Takeform.

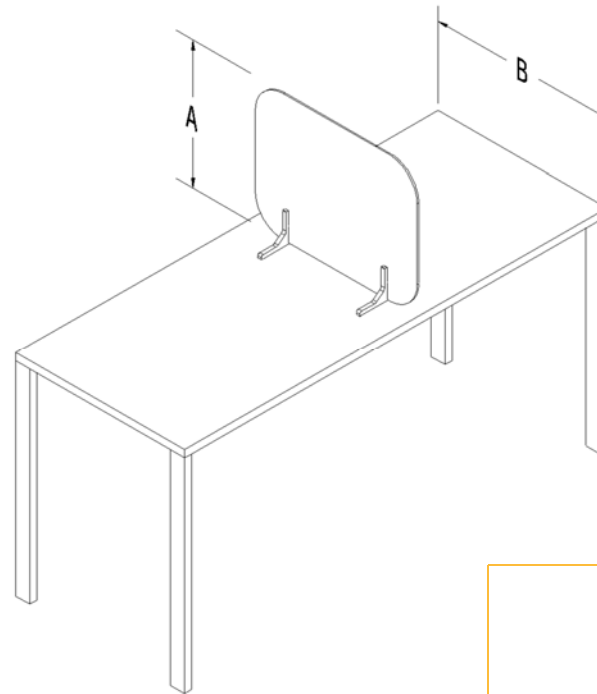

Freestanding Desktop Foot

**Application 3b: Field Measurements**  
 Please complete to ensure accurate sizing of panels and feet.

A : Desired Panel Height (up to 36" max) \_\_\_\_\_

B : Desktop Width \_\_\_\_\_

C : Feet Color (black, white or gray) \_\_\_\_\_

D : Take photos that provide an overall view of workstation system. See page 4 for photo examples. Please note any obstructions.

This area  
 Intentionally  
 left blank.



**K73 Hardware Kit Includes:**

Caliper (1) 900-01120

**Materials/Tools Required:**

Tape Measure

**K73 - ADJOIN Workstation Panel Measurement Kit**

**General Notes Regarding Obstructions:**

If there are obstructions that would prevent mounting of adapters along edges of desking partitions or desktop, document with pictures as they may preclude installation of panels. Stacker Panel adapters will engage with mounting surface 2.25". Also, please note that a 1/8" gap is required between mounting surface and panel as shown.

Possible obstacles for Panel Stacker applications may be cabinets, overhead storage, shelving and monitor arms.

Possible obstacles for adapter-mounted desktop partitions may be framing or leg attachments to underside and near edge of desktop, pedestal drawers, under desk and monitor arms and brackets.



Workstation Photo Example #1:



Workstation Photo Example #2:





**K73 Hardware Kit Includes:**

Caliper (1) 900-01120

**Materials/Tools Required:**

Tape Measure

**Measurement Examples Using Caliper:**

See below figures representing clear (Figure 1) and unclear (Figures 2, 3 and 4) measurement examples using a caliper.

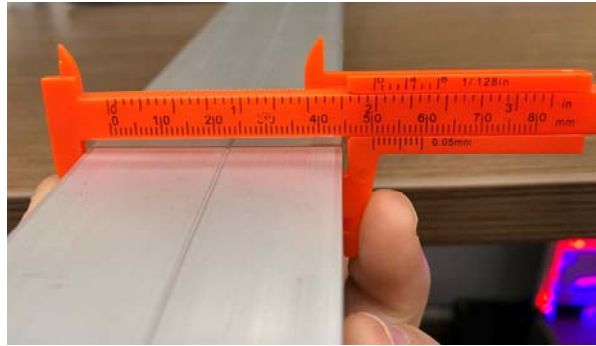

Figure 1: Photo is centered on the entire caliper and in-focus, providing clear caliper reading.

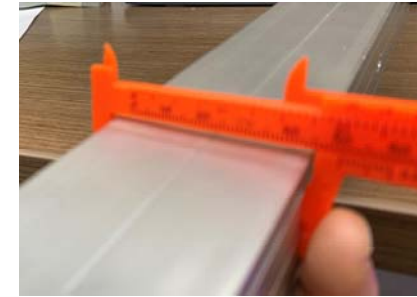

Figure 2: Photo is out of focus so unable to read caliper.



Figure 3: Photo with caliper shown at an angle makes caliper reading difficult and unclear.

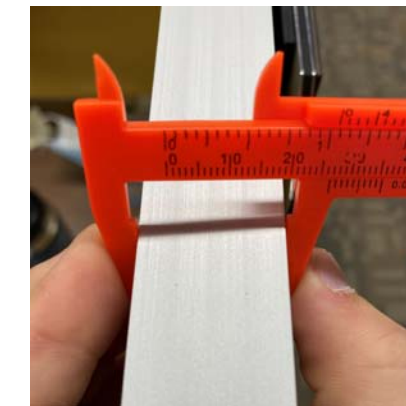

Figure 4: Photo is missing top right of caliper 1/128" scale so unable to determine precise reading.

**Measurement Examples Using Tape Measure:**

See below figures representing clear (Figure 5) and unclear (Figure 6) measurement examples using a tape measure.

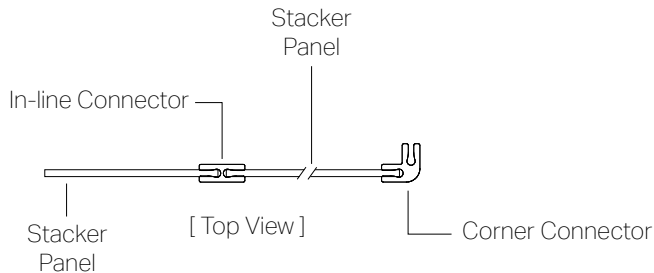

Figure 5: Photo is centered on the tape, providing a clear reading.



Figure 6: Photo at an angle makes reading difficult and unclear.

## Adjoin Panel Connector Worksheet



Adjoin panel stackers utilize various connectors at the intersection points between panels. These small but significant additions to the system ensure precise alignment and spacing while adding stability, especially for larger panels.

To estimate the appropriate type and number of connectors, please select the diagram on the right that most resembles your workstation(s). Don't worry if it's not an exact match – you can describe how it differs below. With that information, we'll calculate the total number of connectors and throw in some extras for good measure.

**Note:** If you can provide Takeform with your furniture plan, you can skip this worksheet.

Describe or sketch your workstation layout below.

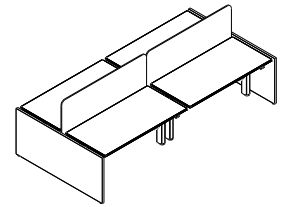

Fig1.  
Bench desking with center spine only.

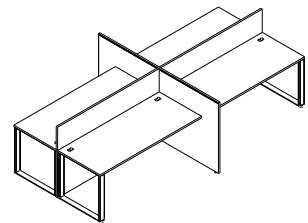

Fig 2.  
Bench desking with center spine and dividers between desks.

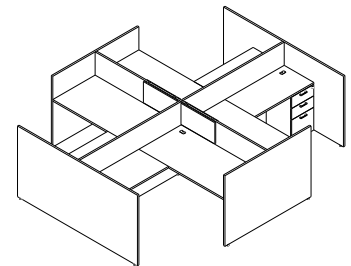

Fig 3.  
Complete workstations with center, side and end panels.

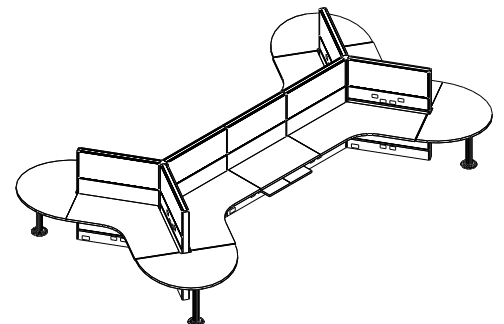

Fig 4.  
Workstations with a "Y" configuration.